

An *aggressive* *new breed* of CtP plate processors

The Raptor 68/85 Thermal

Incorporates leading-edge product design and styling, innovative full featured processing in a compact, space saving "small footprint" application. The processor has been developed in close cooperation with the world's leading thermal plate and equipment suppliers.

Available in two formats, 68 cm (26.8") version covering formats 2-up and 4-up (portrait) and 85 cm (33.5") covering 4-up and 8-up (portrait). As a stand alone unit, or configured for on-line operation with all the market's leading platesetters, this smaller and more efficient processor has more than enough capacity to support the most challenging medium sized clients. The pricing of this CtP processor now also makes it affordable to a substantially broader market segment.

State-of-the-art processing, flexibility, an excellent value for investment and Glunz & Jensens' proven reliability, give the Raptor 68/85 Thermal "Quality by instinct".



Trouble free cleaning

Because of the new snap lock bearings, rollers require no adjustment, they may be cleaned or replaced in just moments.



Convenient servicing

The processor offers easy access for maintenance. Many components such as spray bars and circulation pumps may be removed without tools.



Accurate replenishment

The advanced electronics calculate the amount of media used versus run-time and maintains stable, waste-free processing.



Useful filter drawer

The filter drawer (optional) provides easy access to filter for optimal maintenance - fast and easy operation.



Easy removal of spray bars

Spray bars and adjustment taps are integrated, so that liquid pressure can be quickly adjusted directly on the spray bars.



Removable evaporation lid

Easy removable anti-oxidation cover reduces evaporation from developer section, minimizes the use of chemicals and provides easy access to rollers and brushes.



- Small foot print
- Glunz & Jensen quality and reliability
- Intelligent interface for platesetters
- Tool-free maintenance
- Minimum operational cost
- Remote diagnostics and assistance

Technical specifications

Raptor 68/85 Thermal

Materials	Thermal plates
Capacity	40 - 120 cm/min (15.7 - 47.2" / min)
Material width	675 / 850 mm (26.6 / 33.5")
Material length	290 - 1100 mm (11.4 - 43.3")
Material thickness	0.15 - 0.3 mm (0.006 - 0.012")
Tank content, developer	68: 17 l (4.5 US gal) 85: 22 l (5.8 US gal)
Tank content, wash	68: 11 l (2.9 US gal) 85: 13.5 l (3.6 US gal)
Adjustable temperature, dev.	Ambient - 40°C (104°F) Adjustable from 20 - 40°C (68 - 104°F)
Adjustable temperature, dryer	20 - 60°C (68 - 140°F)
Dwell times at 0.9 m (35.4") / min.	Developer: 24 sec (Dip to dip)
Water supply	Tap water, pressure min 1 bar / 15 psi
Wash	Tap water or recirculation
Water consumption, in re-circulation	200 ml/m ² (0.053 US gal/m ²)
Water consumption, tap water	< 14/16 l/min (3.7/4.2 gal/min) at 0.9 m/min (35.4"/min)
Diameter of rollers	40 mm (1.6")
Warm up time max	< 30 min from 18 - 40°C (64.4 - 104°F)
Level control	Yes
Power	50-60 Hz, 230/400V, 1/3, +/-10
Power consumption	< 3.1 kWh at 230V
Voltage tolerance	+/- 10%
Height	845-930 mm (33.3-36.6") to feed table
Weight (dry)	68: 190 kg (418 lbs) 85: 235 kg (518 lbs)
Weight	Crated: 222 kg (490 lbs)/ 316 kg (697 lbs) Non-crated: 190 kg (419 lbs)/ 235 kg (518 lbs)
Dimensions incl. crating	136 X 120 X 130 cm / 136 cm X 134 X 130 cm 53.5 X 47.3 X 51.8" / 53.5 X 52.7 X 51.2"
Approvals	Complies with CE safety standards UL, c/UL, and GOST-R certified
Positioning:	Recommended for processing an average of up to 250 m ² (2,690 ft ²) of plates per week

Standard equipment: Fully automatic replenishment system based on square meter measurement, Automatic container alarm, Emergency stop.

Accessories: Remote Enabling System, Circulation in wash/wash filter (requires developer filter), Closed stand, Cooling unit -standard capacity 50Hz, Drip tray, Exit table, Feed table, Developer filter, Hand shower, Trolley for cleaning, Configuration kits for: Excel, Thermostar, LT-2 and LH-PLe plates. Interface for various platesetters (please contact Glunz & Jensen for information on interface availability).

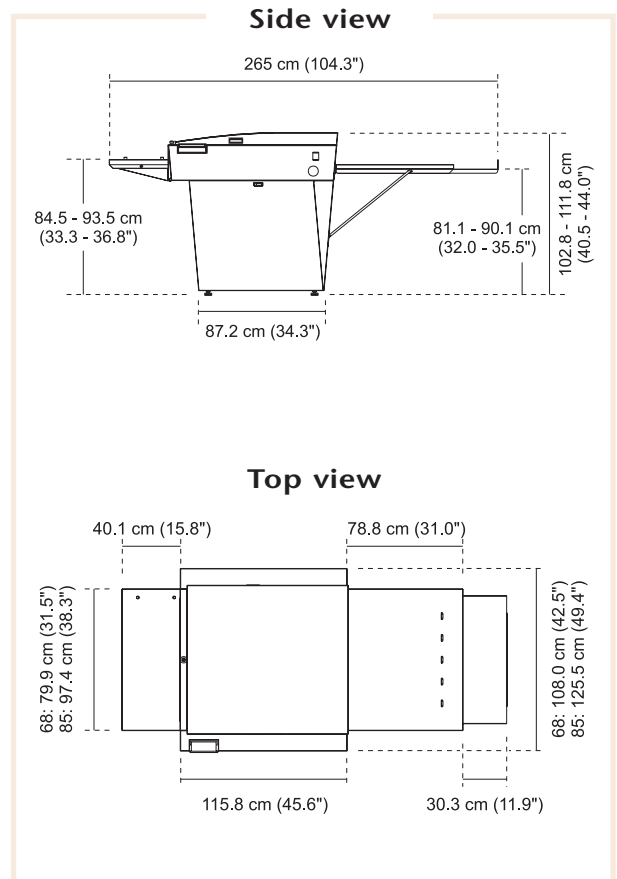

Please note: be aware that the listed data is preliminary, and subject to change.

GLUNZ & JENSEN

Headquarters:
Glunz & Jensen A/S
Haslevvej 13
4100 Ringsted
Denmark
Tel. +45 57 68 81 81
Fax +45 57 68 83 40
e-mail: gjhq@glunz-jensen.com
www.glunz-jensen.com

USA Operations:
Glunz & Jensen, Inc.
21405 Business Court
Elkwood, VA 22718-1757
USA
Tel. +1 540 825-7300
Fax +1 540 825-7525
e-mail: usva@glunz-jensen.com