

# KATANA 5040R/5055R

High-end Imagesetter

CTF



Innovation & Reliability

# The Efficiency and Beauty of a Japanese Longsword

THE JAPANESE LONGSWORD, COMMONLY KNOWN AS THE KATANA, IS A MASTERPIECE OF SWORDMAKING, FAMED FOR ITS BALANCE, STRENGTH, AND ELEGANCE. DAINIPPON SCREEN HAS RECENTLY DEVELOPED A MASTERLY PAIR OF IMAGESETTERS INSPIRED BY THE BEAUTY AND EFFICIENCY OF THE JAPANESE KATANA. COMBINING THE SPEED DEMANDED FOR TODAY'S TIGHT DEADLINES WITH OUTPUT THAT, LIKE THE JAPANESE KATANA, IS A WORK OF ART, THE NEW KATANA 5000R SERIES IMAGESETTERS ARE THE PERFECT ANSWER TO TODAY'S PREPRESS NEEDS.

THE KATANA 5000R SERIES IMAGESETTERS OFFER REMARKABLE REPEATABILITY – THE KIND OF REPEATABILITY REQUIRED FOR HIGH-QUALITY OUTPUT. WHAT'S MORE, THIS REPEATABILITY IS AVAILABLE AT AMAZING SPEEDS, MAKING THE NEW KATANAS TWO OF THE FASTEST IMAGESETTERS IN THE WORLD. WITH EXPOSURE WIDTHS OF UP TO 575 MM (22.6") FOR THE B2 FORMAT KATANA 5055R AND 398 MM (15.6") FOR THE B3 FORMAT KATANA 5040R, THE KATANA SERIES IMAGESETTERS MAKE IT EASY TO OUTPUT JUST ABOUT ANY 2-PAGE OR 4-PAGE JOB QUICKLY AND ACCURATELY.

THE KATANA 5000R SERIES IMAGESETTERS CAN OUTPUT SEVERAL TYPES OF MEDIA, INCLUDING FILM, PAPER, AND FLEXIBLE PLATES. WITH THEIR SUPERIOR REGISTRATION ACCURACY AND SIX DIFFERENT IMAGING RESOLUTIONS, THE NEW KATANA 5000R SERIES IMAGESETTERS ARE IDEAL FOR INEXPENSIVE, FAST, AND HIGH-QUALITY OUTPUT ONTO A VARIETY OF MEDIA.



## Advanced film transport for high-quality output

Perfect for any use

### SUPERIOR REGISTRATION ACCURACY

The Katana 5040R and Katana 5055R's improved film transport system assures consistent media placement. Thanks to this new system, the Katana 5000R series

imagesetters offer a remarkable registration accuracy of  $\pm 25$  microns ( $\pm 1$  mil) for four continuous separations. This makes it easy to get high-quality four-color printed output every time.

In fact, the Katana's superior registration is more than adequate even for difficult tasks, such as quad output onto a single film. In quad output, all four colors are output onto a single sheet of media. Quad output saves both time and materials, but requires much greater registration accuracy than standard four-film four-color output. Thanks to the Katana 5000R series imagesetters' superior imaging and film transport systems, registration is good enough even for high-quality quad output.

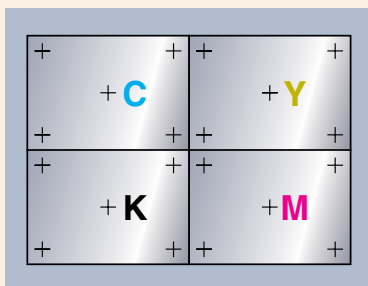

The imaging system consists of a spinning five-facet polygon mirror that transmits the imaging beam through an  $f_{\theta}$  lens before allowing the beam to reach the media. The maximum spinning speed of the polygon mirror is 14,400 rpm, which translates across the five facets into an effective spin rate of 72,000 rpm, achieved without the usual accompanying problems of mirror vibration and image deterioration. The  $f_{\theta}$  lens is shaped so that it narrows the beam to a small point, preventing distortion of the image even at the edges of the media.

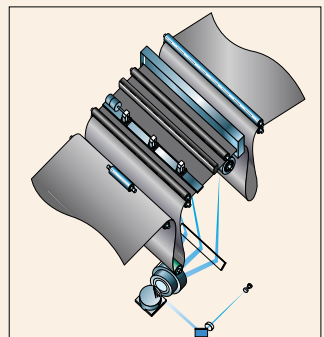

# Exceptional quality and productivity

Cutting-edge data transmission and imaging technology

## Even higher speed output

Fast transmission and reception capabilities, enhanced by advanced dedicated buffering technology, support continuous imaging by assuring that data is transmitted to the imagesetter with a minimum of delay.

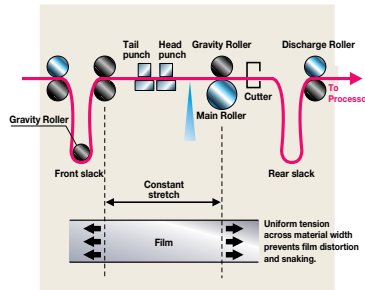

## Superior imaging system

The Katanas' imaging system employs a five-facet polygon mirror that reflects a precision laser diode beam through a specially designed  $f \theta$  lens to narrow the beam and project it onto an exact point. This precise imaging system, paired with the Katanas' superior transport system, helps these units image at a quality rivaling that of internal drum imagesetters, even at high resolutions and line rulings. Best of all, with the Katana 5000R series, the resulting high repeatability and accuracy is available on a variety of media at high speed.

# A system you can tailor to your needs

Versatile and customizable

## A variety of punch formats

The Katana 5000R series feature a wide variety of punch formats, including optional tail punch support. Punch formats include Screen, Stoesser, Protocol, Bacher, and Western Lithotech. Custom punch formats can also be supported. On-site punch system installation is available, so users can choose to change punch formats even after the unit has been installed. Internal punch systems take the effort out of registration punching, reducing the strain on operators and increasing productivity even further.

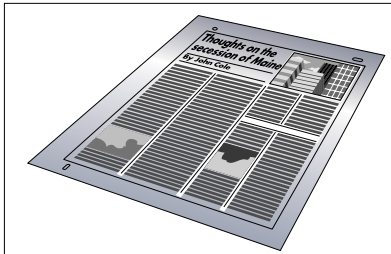

## A choice of output media

The Katana 5000R series support media from 10 to 24 inches wide\* and can output to a variety of media, including film, RC paper, and flexible plates\*\*. Flexible plates make it easy to get fast, high-quality four-color plate output right from the Katana 5000R series imagesetters. The superior repeatability and registration accuracy of the Katana 5000R series imagesetters assure high quality no matter what the media, and flexible plate support makes it easy to create a fully digital prepress production workflow by turning the Katana 5000R series imagesetters into entry-level CTP output devices.

\* 10, 12, 14, 16, 18, 20, 22, and 24 inch widths are available for the Katana 5055R; 10, 12, 14, and 16 inch widths are available for the Katana 5040R.

\*\* Flexible plates can be set in 1 mm increments from a minimum of 254 mm (10") to a maximum of 615 mm (24.2").

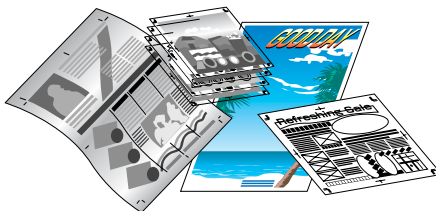

## Optional LD-M1060 processor

The LD-M1060 processor is specially designed for inline use with the Katana 5000 series imagesetters. A compact unit, it keeps the imagesetter/processor's combined footprint down even further thanks to its bridgeless design. The processor's internal tank is 20% deeper than those of similar models, making a longer transport stroke possible. The extra length helps the processor keep up with the Katana series imagesetters' extremely high imaging speeds. Furthermore, the LD-M1060's advanced processor tank design reduces chemical evaporation to provide more stable processing quality.



Processor **LD-M1060**

## High-speed RIPs for better productivity

The Katana 5000R series are compatible with all of Dainippon Screen's advanced RIPs. The imagesetters' Fast-PIF data interface assures great productivity no matter what RIP is used. With the combination of Screen's high-quality RIPs and the Katana 5000R series imagesetters, it's easy to get high-quality, full-color A4 2-up or 4-up output.

The Harlequin ScriptWorks-based HQ-510 RIPs feature PostScript®3™ compatibility and drive the Katana series efficiently. Trueflow Rite is an advanced workflow system based on the latest core technology from Adobe. Both the HQ-510 RIPs and Trueflow support PDF 1.3 and 1.4 input.



Software RIP **HQ-510PC**

## Space requirements

Note: The above diagrams show the Katana 5000R series with optional inline processor.

	A	B	C	D	E	F	G
mm	1,003	988	1,060	778	922	348	2,063
inches	39.5	38.9	41.8	30.7	36.3	13.7	81.3

## KATANA 5040R/5055R specifications

Model name	FT-R 5040R	FT-R 5055R
Exposure system	Flatbed imaging system, 635 nm laser diode, polygon mirror	
Resolutions	1,000/1,200/1,500/1,800/2,400/3,000 dpi	
Registration accuracy	±25 microns (±1 mil) on overlaying sheets (film) ±50 microns (±2 mil)* on overlaying sheets (flexible plates)	
Media types	He-Ne sensitive film or paper, flexible plates	
Media widths	Film and paper: 254 mm (10") 305 mm (12") 355 mm (14") 406 mm (16") Flexible plate: From 254 to 406 mm (10" to 16"), in 1 mm increments	Film and paper: 254 mm (10") 305 mm (12") 355 mm (14") 406 mm (16") 457 mm (18") 508 mm (20") 558 mm (22") 609 mm (24") Flexible plate: From 254 to 615 mm (10" to 24.2"), in 1 mm increments
Max. imaging width	398 mm (15.6")	Film and paper: 575 mm (22.6")** Flexible plate: 556 mm (21.8")**
Media roll length	61 m (200')	
Media output	To output cassette or inline processor	
Output cassette capacity	15 m (49.2')	
Compatible RIPs	HQ-510PM, HQ-510PC, Trueflow Rite	
I/F change	Fast-PIF	
Weight	200 kg (440 lbs.)	
Power requirements	Single phase 100 V to 120 V, 0.4 kW, or single phase 200 V to 240 V, 0.4 kW	
Environment	Operating: 18 to 28°C (64.4 to 82.4°F), 50 to 70%RH Down Time: 15 to 33°C (59.0 to 91.4°F), 30 to 80%RH Storage: 0 to 50°C (32.0 to 122.0°F), 10 to 80%RH	
Punch unit (optional)	Stoesser, Bacher, Protocol, Western Lithotech, Screen, and other pin systems	
Inline processor (optional)	LD-M1060	

\* Registration accuracy is guaranteed only for flexible plates wider than 508 mm (20").

\*\* Image quality can only be guaranteed for images up to a width of 550 mm (21.6").

### Notes on achieving register accuracy

1. Proper register accuracy is only possible if all four plates are output under the same conditions (temperature, humidity).
2. Proper register accuracy is only possible for plates where the length of the plate in the secondary scanning direction is less than 1.4 times the length of plate in the primary scanning direction.
3. Register accuracy is based on the center register mark.
4. Register accuracy requires that all the plates used are consistent in width.

## DAINIPPON SCREEN MFG. CO., LTD.

### HEAD OFFICE

• Teranouchi-agari, 4-chome, Horikawa-dori, Kamigyo-ku, Kyoto, 602-8585 Japan/Phone +81-75-414-7610/Fax +81-75-414-7608

### SCREEN (USA)

• 5110 Tollview Dr., Rolling Meadows, IL 60008, USA/Phone 847-870-7400/Fax 847-870-0149 www.screenusa.com

### DAINIPPON SCREEN (DEUTSCHLAND) GmbH

• Mündelheimer Weg 39, 40472 Düsseldorf, Germany/Phone 0211-472701/Fax 0211-4727199/Telex 858-4438 DSDD D

### DAINIPPON SCREEN (U.K.) LTD.

• Michigan Drive, Tongwell, Milton Keynes, Buckinghamshire MK15 8HT, UK/Phone 01908-848500/Fax 01908-848501 www.screen.co.uk

### DAINIPPON SCREEN (NEDERLAND) BV

• Bouwerij 46, 1185 XX Amstelveen, Holland/Phone 020-4567800/Fax 020-4567805 www.screeneurope.com

### SCREEN FRANCE

• Z.I. Paris Nord II, 12 Rue des Chardonnerets, B.P. 50315, F-95940 ROISSY C.D.G. Cedex, France/Phone 1-48-17-86-00/Fax 1-48-17-86-01

### DAINIPPON SCREEN SINGAPORE PTE. LTD.

• 29, Kaki Bukit View, Kaki Bukit Techpark II, Singapore 415963/Phone 67493833/Fax 67499010 www.screensp.com.sg

### DAINIPPON SCREEN (CHINA) LTD.

• 6th Floor, 414 Kwun Tong Road, Kwun Tong, Kowloon, Hong Kong/Phone 2953-0038/Fax 2755-8683

### Beijing office /Phone 010-6708-9271, 9272, 9273/Fax 010-6708-9395

### Shanghai office /Phone 021-6466-4501/Fax 021-6466-4503

### Guangzhou office/Phone 020-3891-1112/Fax 020-3891-1036

### DAINIPPON SCREEN (AUSTRALIA) PTY. LTD.

• 4F No. 126-1, Ming Tsu West Rd., Taipei, Taiwan/Phone 02-25862711/Fax 02-25914367

### DAINIPPON SCREEN (KOREA) CO., LTD.

• 10th Yonsei Bongnae B/D 48-3, 1Ga, Bongnae-Dong, Joong-Gu, Seoul 100-161, Korea/Phone 02-7766-786/Fax 02-7766-787

### DAINIPPON SCREEN (AUSTRALIA) PTY. LTD.

• Unit 2, 207-209 Young Street, Waterloo, NSW 2017, Australia/Phone 02-9310-1314/Fax 02-9310-3566

Internet web site : [www.screen.co.jp](http://www.screen.co.jp)  
[www.screenusa.com](http://www.screenusa.com)  
[www.screeneurope.com](http://www.screeneurope.com)

- This brochure was made using Spekta 2 screening.
- Printed on recycled paper.

We reserve the right to alter product design and specifications without prior notice.